

AKRONEX[®]

INTERNATIONAL



AKRONEX 227

Clean Agent Fire Suppression Systems

Worldwide Solutions



www.akronex.com

AKRONEX 227 Fire Suppression Systems

It is a more ideal solution to use clean-gas fire-extinguishing technology where water is more harmful than fire for datas, devices and people.

All products are designed and certified according to national and international standards. Compared to conventional systems, the benefits of Akronex 227 include:

- Faster than water extinguishing systems
- Safe for human life, environmental, extended life suppressant,
- No residue, No waste,
- Prevents damage caused by smoke, ash, and wetness,
- Does not damage protected equipment and objects.
- Not conductive, does not damage the operating function of electronic devices.



Activity Areas

- Data Center, Telecommunication, Information Technologies
- Energy Sector and Auxiliary Industries
- Museums, Libraries, Schools, University Campus
- Health Industry
- Public Institutions
- Manufacturing Sector, Logistic Centers
- Oil, Gas and Hydrocarbon Industry
- Wind Power Plants, Hydro Power Plants, Solar Power Plants, Geothermal Power Plants

Fast Suppression

It detects fire precisely and quickly from the first phase of the fire. The detection zone, which works with the cross zone principle, allows detection of two zonsets and discharges HFC-227ea gas to the area in less than 10 seconds. Thus, the extinguishing process is started and the extinguishing process is completed if the gas remains in the place for at least 10 minutes.

Different Detect Solutions

It allows to use various detection methods according to ambient conditions of enclosed volumes. The smoke detector, heat detector, rate of rise heat detector, linear type heat detector, flame detector or spark detector can be used according to the device or the data in the area.



AKRONEX 227

Modular Systems

Other Components

- Akronex Cylinder
- Gas
- Accessories
- Nozzles
- Diaphragm and embellishment plate

List Of Materials

Protection cap for cylinders and label is included to the system.

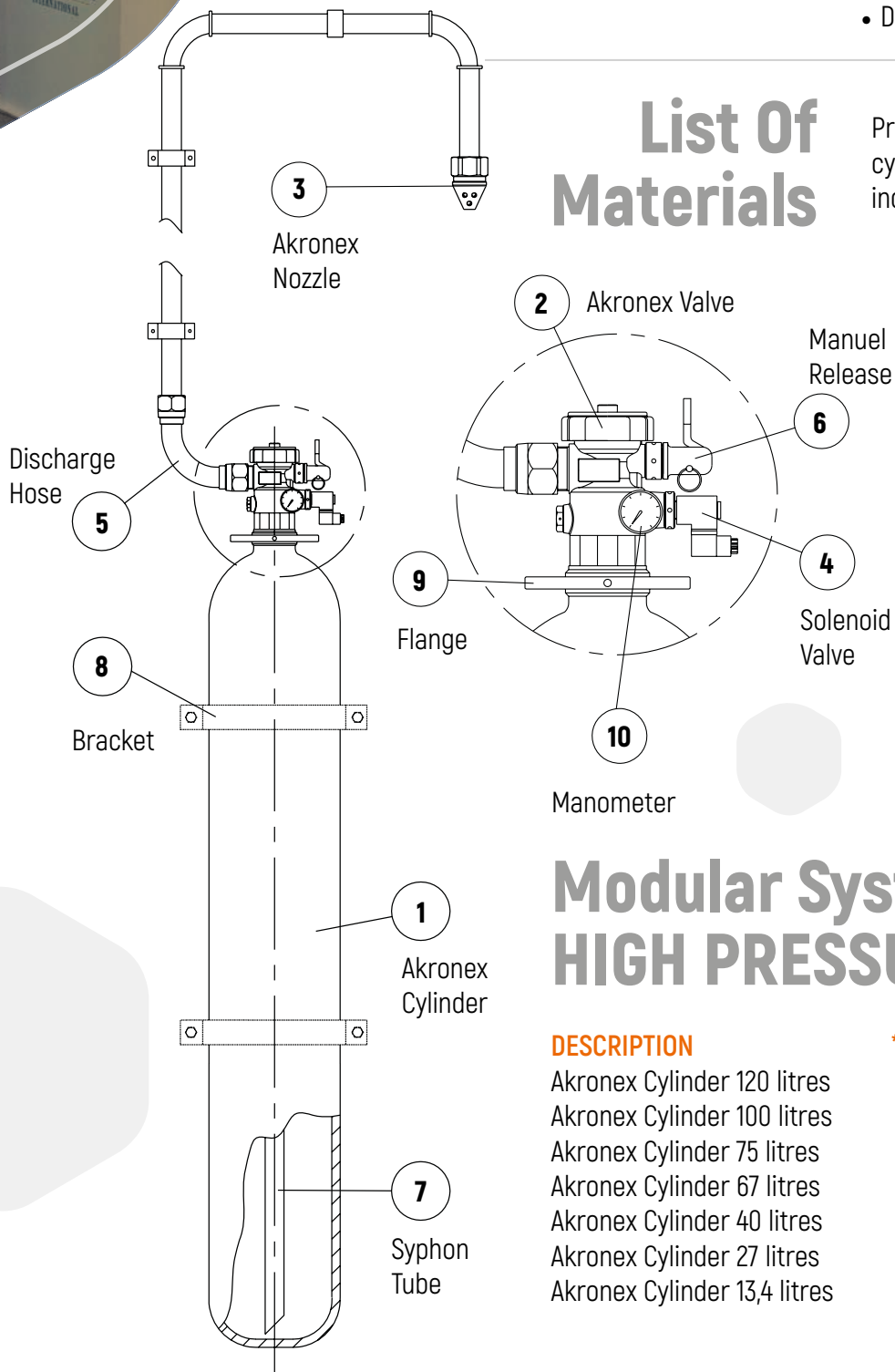

Gas

Name
HFC-227 ea

Modular System HIGH PRESSURE (42 Bar)

DESCRIPTION

Akronex Cylinder 120 litres	138,00 kg
Akronex Cylinder 100 litres	115,00 kg
Akronex Cylinder 75 litres	88,00 kg
Akronex Cylinder 67 litres	77,00 kg
Akronex Cylinder 40 litres	48,00 kg
Akronex Cylinder 27 litres	30,80 kg
Akronex Cylinder 13,4 litres	15,40 kg

*RECOMANDED FILLING

138,00 kg
115,00 kg
88,00 kg
77,00 kg
48,00 kg
30,80 kg
15,40 kg

Akronex 227 Valves



Akronex40



Akronex20

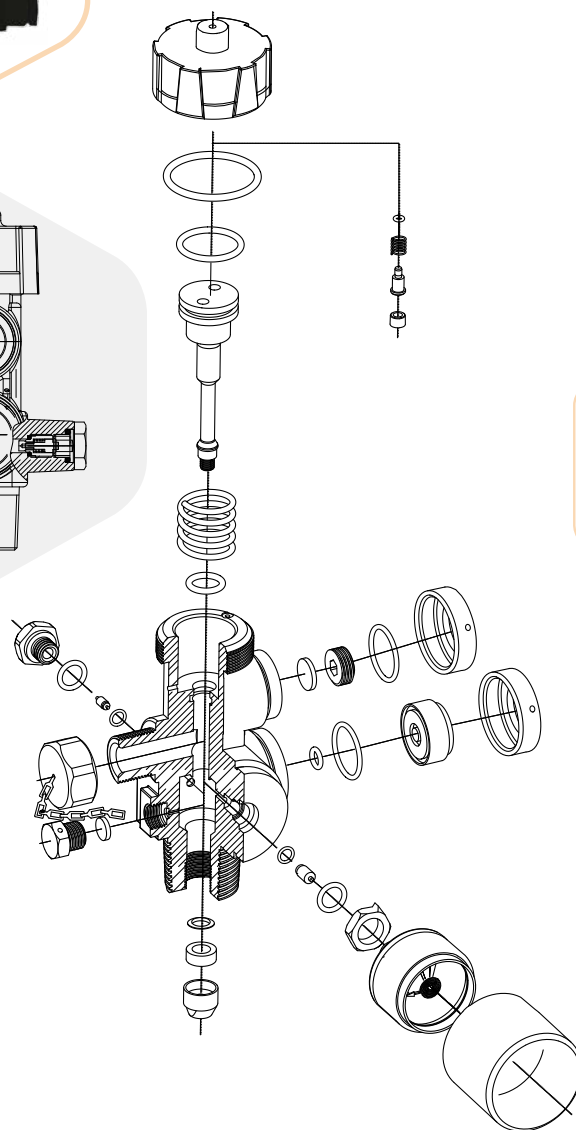
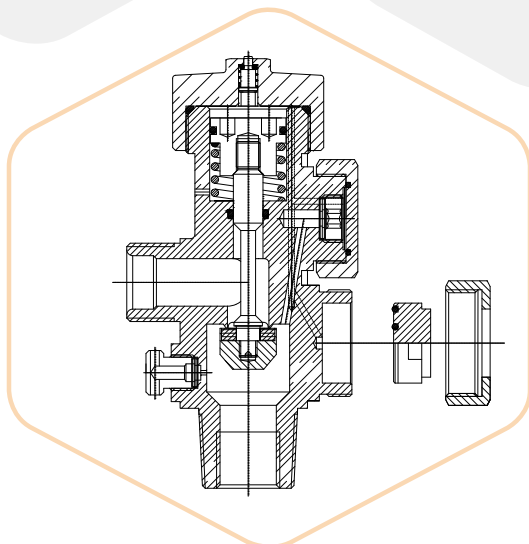
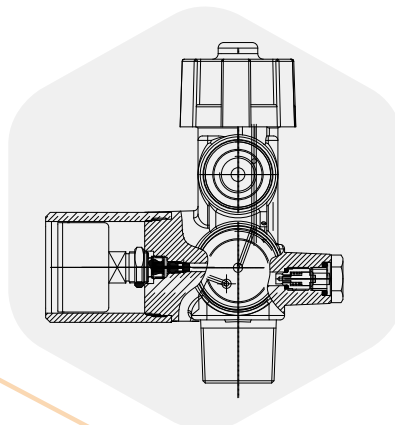

	AKRONEX20	AKRONEX40
Material	Brass	Brass
Test Pressure	88 Bar	88 Bar
Working Pressure	42 Bar	42 Bar
Working Temperature Range	-20 °C to +50 °C	-20 °C to +50 °C
Pressure Gauge Connection	M10x1	M10x1
Manual Release Device Connection	M30x1.5	M30x1.5
Solenoid Actuator Connection	M36x1.5	M36x1.5
Valve Outlet Connection	G.3/4"	G.1 1/2"
Valve Seat Diameter	1"-11.5 NPT	G.2 1/2"-12 UN



Stop Button



Battery



Sounder / Flasher

ELECTRONIC SYSTEM PARTS

EP203 Automatic Extinguisher Panel



Approvals/certifications	Certified to EN12094-1 and EN54-2/4 by the LPCB (176c) / (0832-CPD-0794).
Mains supply	230V 50/60Hz.
Mains rated current	810mA max.
Internal power supply	19V-28.5V (27V nominal). Ripple 7V maximum (battery fault)
No. of detector zone circuits	3 @ 19-28Vdc (Max. length per circuit is 250m)
Product dimensions (mm)	439 W x 276 H x 70 D mm (back box); 467 W x 293 H x 29 D mm (lid).
Weight	4.2kg (without batteries).
Operating conditions/temperature	-5°C to +40°C. Max relative humidity: 95%.
IP Rating	IP30.

Enclosure Integrity Test

NFPA 2001 requires an enclosure integrity test to check for air leaks and holding times as part of the system acceptance procedure. This test can be carried out using a calibrated blower door fan test unit by certified tester.



Product Code	Explanation	Specifications
ECO 1000	Detector Base	<ul style="list-style-type: none"> •Low profile design •Low current draw •Operates on 12 and 24VDC Systems •Remote alarm test feature •Easy Maintenance
ECO 1002	Multi Criteria Photoelectric Smoke / Thermal Detector	
ECO 1003	Photoelectric Smoke Detector	
ECO 1005	Rate of Rise Thermal Detector	



Smoke, Thermal and Multi Detectors

HFC-227ea Environment Friendly Fire Extinguishing Gas

While the world is making rapid technological progress, at the same time people are in a race against adverse effects on ecological balance.

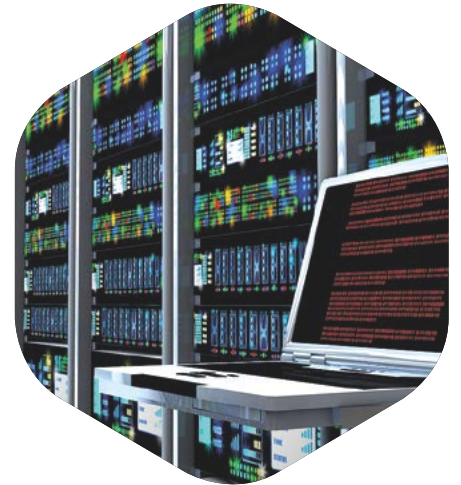

AKRONEX International Fire Engineering Inc.

AKRONEX International was established in 2007 and operates in the fire sector, which has become a must in technology age.

Our company, which specializes in "Automatic Fire Extinguishing Systems", attaches great importance to the research and development which is the necessity of information age, and follows the technological developments in the world closely and adopts the principle of producing service with the latest products with international qualifications and approvals.

AKRONEX International, which exports to many regions of the world, continues to increase its production and communication through this export network.

OUR MISSION

AKRONEX International has made the principle of producing environment friendly products with constantly thinking of innovation by investing in research and development to make continuous production of national and international standards.

OUR VISION

By providing fully promote our brand communication, strengthened in the international area, Becoming Turkey's leading manufacturers in the production of Automatic Fire Extinguishing Systems and compete with the world-class brands.



AKRONEX
INTERNATIONAL



AKRONEX



People who benefit more from nature and world blessings by the development of technology have also caused to occur pollution at the same time.

HFC-227ea (Clean Agent) and fire protection systems are a responsible choice to protect nature.



AKRONEX[®]
INTERNATIONAL



Worldwide Solutions

In Automatic Fire Suppression Systems

- Albania
- Armenia
- Azerbaijan
- Bangladesh
- Cyprus
- Ethiopia
- France

- Georgia
- Germany
- India
- Iran
- Iraq
- Italy
- Kuwait

- Libya
- Maldives
- Moldova
- Oman
- Pakistan
- Qatar
- Russia

- Saudi Arabia
- Senegal
- Serbia
- Spain
- Tanzania
- Tunisia
- Turkmenistan

gpositveajans.com | 0850 840 80 45



AKRONEX INTERNATIONAL FIRE ENGINEERING INC.
CENTER: İçmeler Mah. Reis Sok. No:19/2 Tuzla, İstanbul, TURKEY
Phone: +90 216 442 88 24 -25 | Fax: +90 216 442 88 26 | E-mail: info@akronex.com

www.akronex.com

